



EHAOS AMPLIFIERS **Service Manual**

MODEL: CH650

SPECIFICATIONS

Maximum power output (2 Ohms): 250W x 4ch

RMS power Output: 100W x 4ch

Bridged Power Output: 500W x 2ch

Frequency response: 9 - 50KHz

Harmonic distortion: 0.01%

S/N Ratio: 130dB

Power Source Voltage: 14.4V

Ground: Negative

Power consumption: 25A(with 125Wx2 rated output)

External dimensions: 300(W)x65(H)x378(D)mm

To engineers in charge of repair or inspection of our products.

Before repair or inspection, make sure to follow the instructions so that customers and Engineers in charge of repair or inspection can avoid suffering any risk or injury.

1. Use specified parts.

The system uses parts with special safety features against fire and voltage. Use only parts with equivalent characteristics when replacing them. The use of unspecified parts shall be regarded as remodeling for which we shall not be liable. The onus of product liability (PL) shall not be our responsibility in cases where an accident or failure is as a result of unspecified parts being used.

2. Place the parts and wiring back in their original positions after replacement or re-wiring. For proper circuit construction, use of insulation tubes, bonding, gaps to PCB, etc, is involved. The wiring connection and routing to the PWB are specially planned using clamps to keep away from heated and high voltage parts. Ensure that they are placed back in their original positions after repair or inspection. If extended damage is caused due to negligence during repair, the legal responsibility shall be with the repairing company.

3. Check for safety after repair. Check that the screws, parts and wires are put back securely in their original position after repair. Ensure for safety reasons there is no possibility of secondary problems around the repaired spots. If extended damage is caused due to negligence of repair, the legal responsibility shall be with the repairing company.

4. Caution in removal and making wiring connection to the parts for the automobile. Disconnect the battery terminal after turning the ignition key off. If wrong wiring connections are made with the battery connected, a short circuit and/or fire may occur. If extensive damage is caused due to negligence of repair, the legal responsibility shall be with the repairing company.

5. Cautions regarding chips.

Do not reuse removed chips even when no abnormality is observed in their appearance. Always replace them with new ones. (The chip parts include resistors, capacitors, diodes, transistors, etc). The negative pole of tantalum capacitors is highly susceptible to heat, so use special care when replacing them and check the operation afterwards.

6. Cautions in handling flexible PCB

Before working with a soldering iron, make sure that the iron tip temperature is around 270... Take care not to apply the iron tip repeatedly (more than three times) to the same patterns. Also take care not to apply the tip with force.

7. Turn the unit OFF during disassembly and parts replacement. Recheck all work before you apply power to the unit.

EXPLODED VEIW

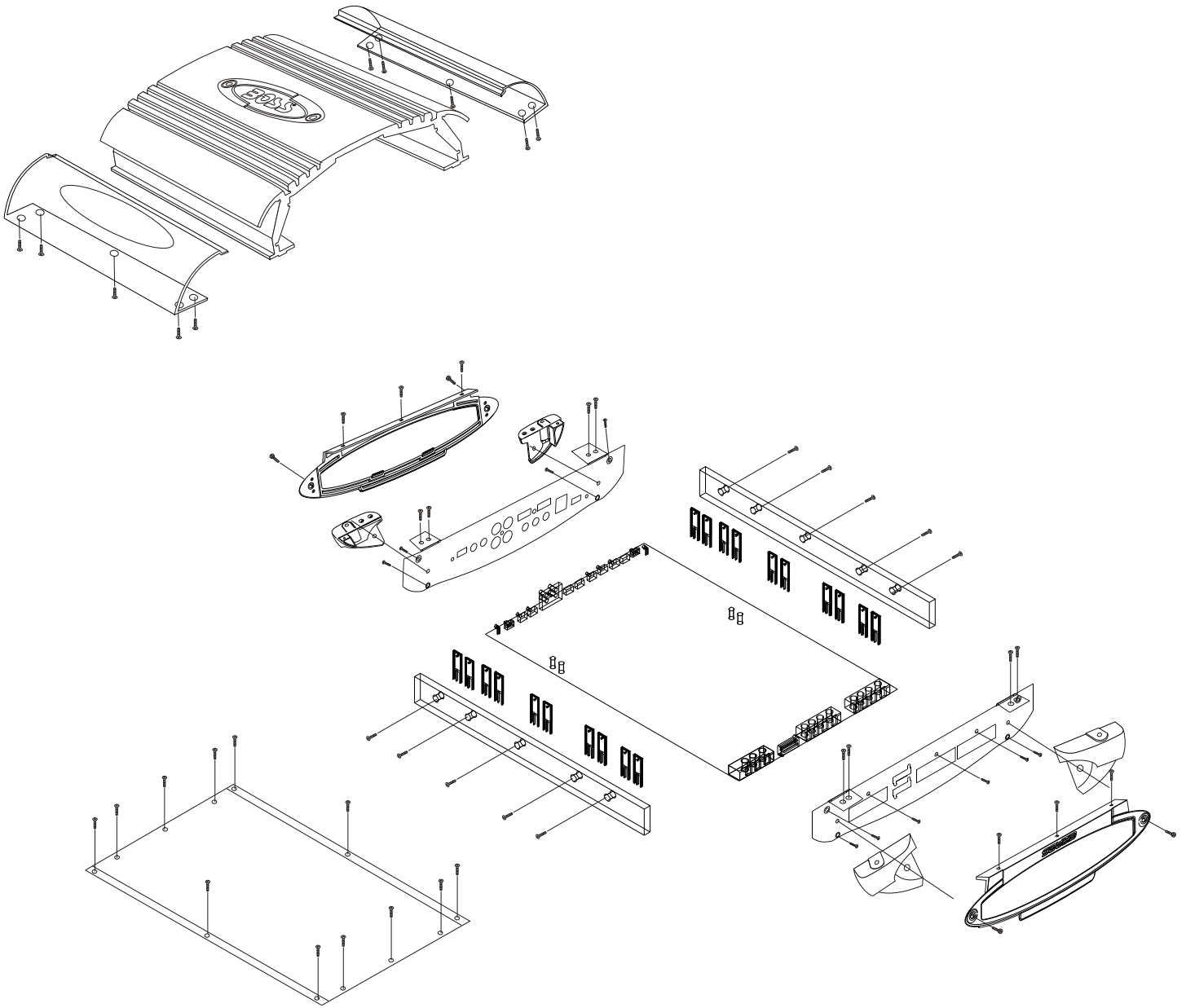

PRINTED CIRCUIT BOARD

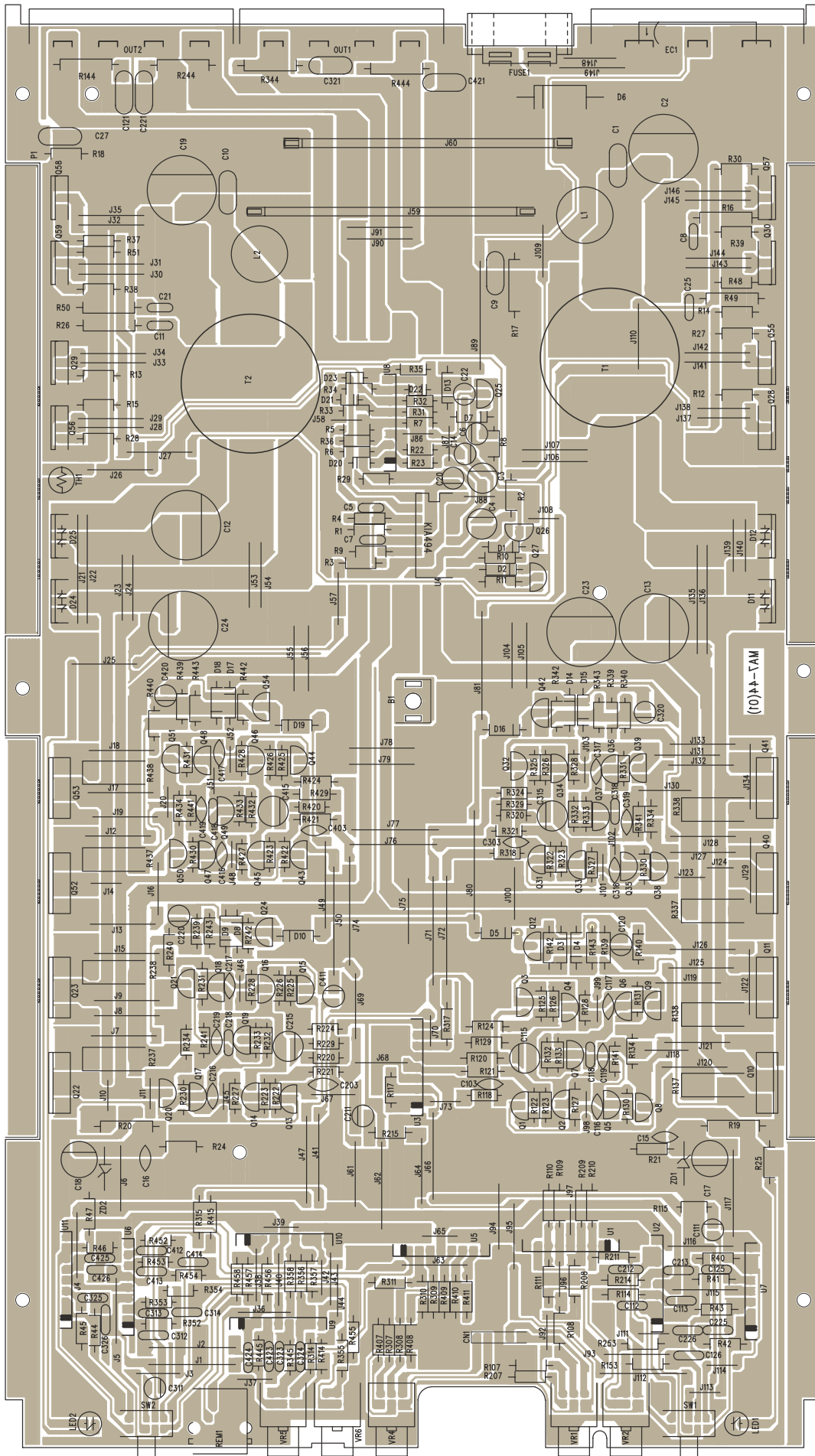

CIRCUIT DIAGRAM 1

CH650

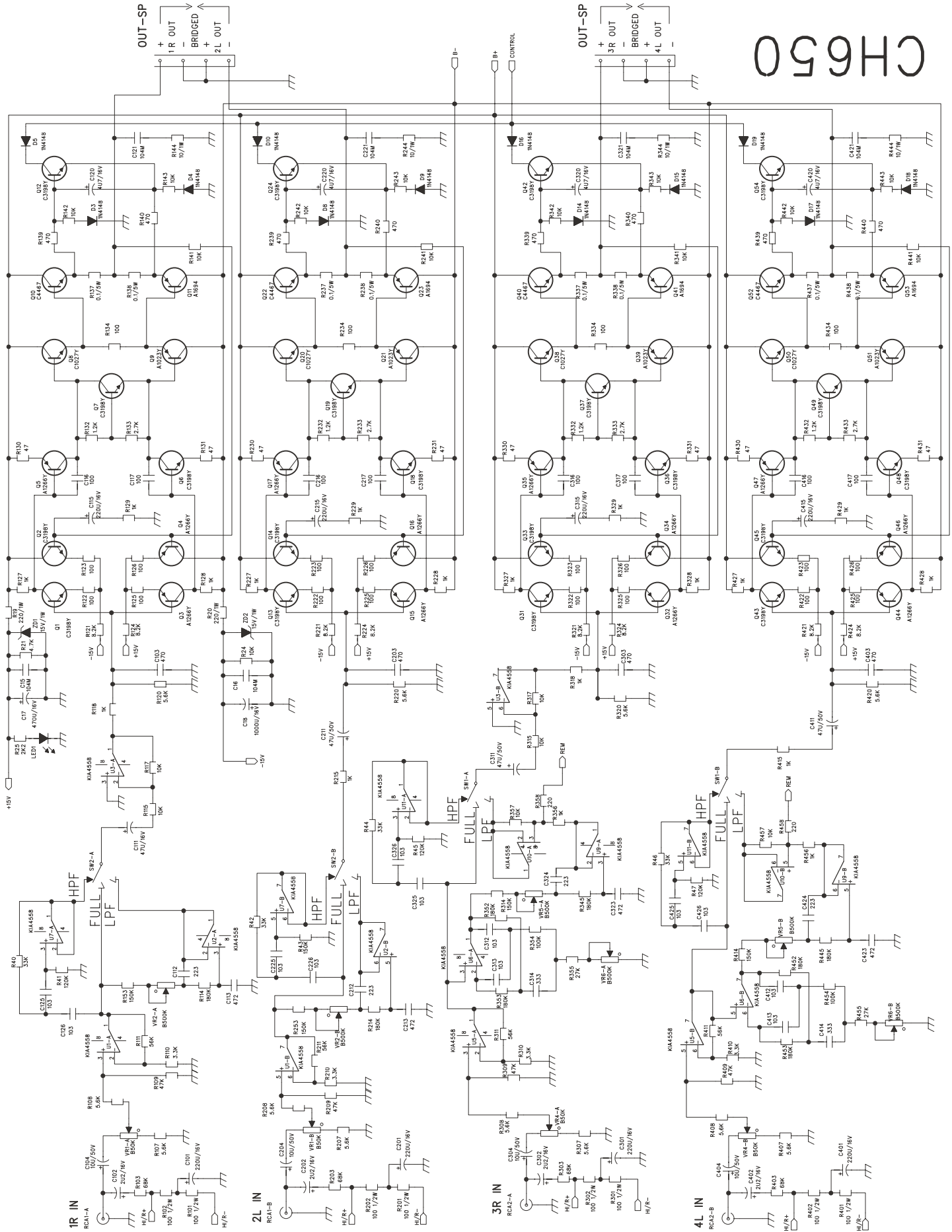

CIRCUIT DIAGRAM 1

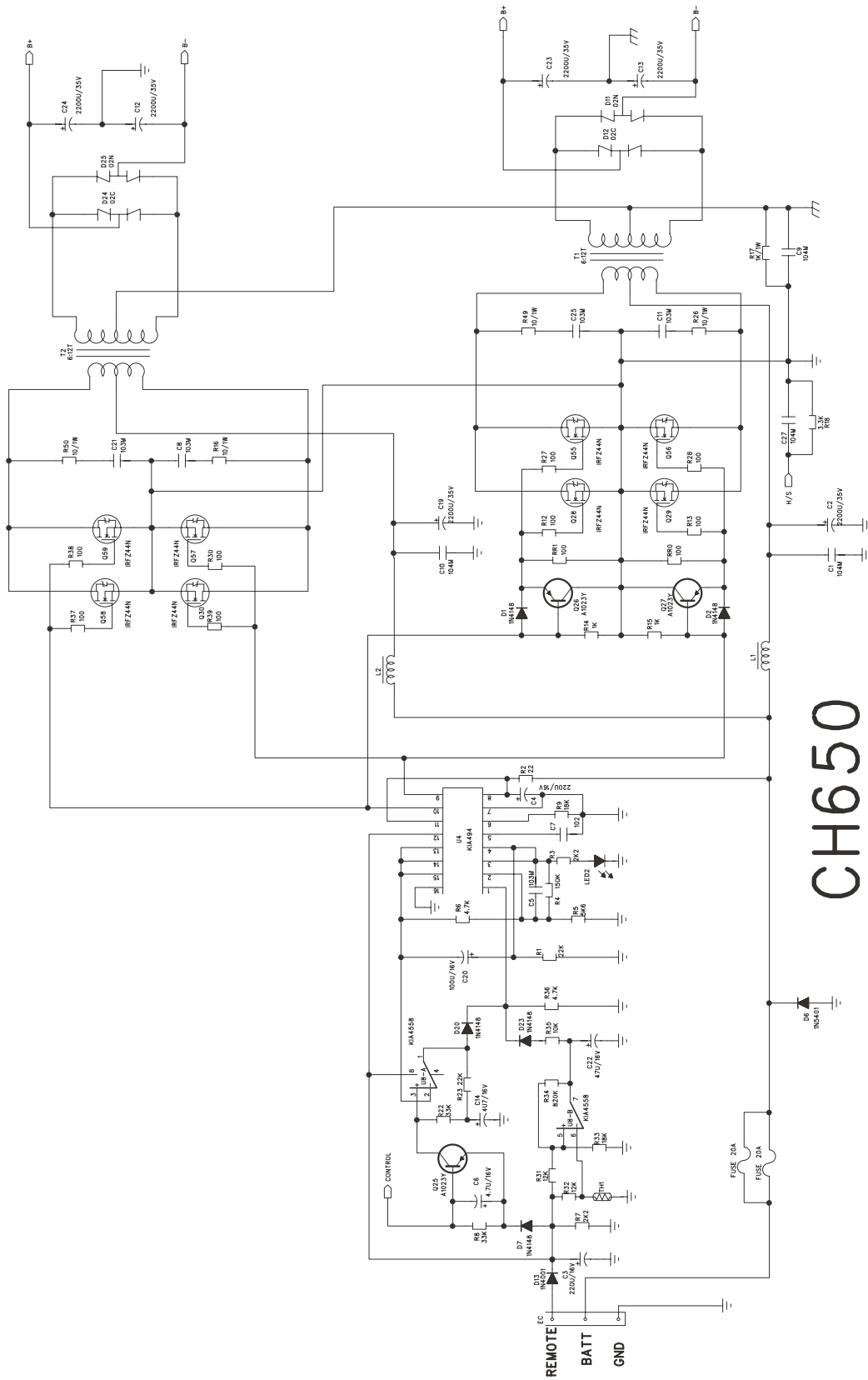

CH650

PARTS LIST - 1

code	desc	remark	qty_need
CR-40091X0-VOS00	RCA Jack	RCA1	1
CT-SOCKET0-3MA7A	Power terminal		1
CT-SOCKET0-4MA7A	Speaker terminal		2
CW-50000X0-H0025	High input Jack	HI IN	2
CW-50000X0-V0025	5 pin connection jack	CN2	1
EC-C4104X0-Z6769	C Cap 0.1(Z)	C15,16	2
EC-C4220X0-D5050	C Cap 22PF(D)	C119,219,319,419	4
EC-C4680X0-J5050	C Cap 68PF(J)	C116,117,216,217,316,317,416,417	8
EC-E2107X0-M50A1	E Cap 100UF/16	C20	1
EC-E2227X0-M63A1	E Cap 1000/16V	C3,4,101,115,201,215,301,315,401,415	10
EC-E2476X0-M50A1	E Cap 220UF/16	C22	1
EC-E2477X0-MA0A3	E Cap 470UF/16	C17,18	2
EC-E4106X0-M50A1	E Cap10UF/50V	C(1,2,3,4)04,(1,2,3,4)11	8
EC-E4225X0-M50A1	E Cap 2.2UF/50	C102,202,302,402	4
EC-E4475X0-M50A1	E Cap 4.7UF/50	C6,14,120,220,320,420	6
EC-E6228X0-MA3B5	E Cap 2200/35V	C2,12,13,19,23,24	6
EC-M5102X0-J5590	Mylar Cap 0.001	C7,103,203,303,403	5
EC-M5103X0-J5590	Mylar Cap 0.01	C5,8,11,21,25,118,218,318,418,312,313,412,413,(1,2,3,4)25,(1,2,3,4)26	21
EC-M5104X0-JA0A3	Mylar Cap 0.1	C1,9,10,27,121,221,321,421	8
EC-M5223X0-J66A3	Mylar Cap 0.022	C112,212,324,424	4
EC-M5333X0-J82A1	Mylar Cap 0.033	C314,414	2
EC-M5472X0-J5090	Mylar Cap 0.0047	C113,213,323,423,	4
		D12,25	
ED-R2502C0-H0000	ESAC25-02C		2
ED-R2502N0-H0000	ESAC25-02N	D11,24	2
ED-R4001X0-H0000	Diode IN-4001	D13	1
ED-R5401X0-H0000	Diode IN-5401	D6	1
ED-Z15VXX0-H4744	ZENER IN4744	ZD1,2	2
EE-C23X5X0-10302	LED Red 3MM	LED2	1
EE-C53X5X0-10302	LED Green 3MM	LED1	1
EO-IMA744X-VXXX6	Transformer	T1,2	2
EO-VMA924X-V8025	coil	L1,2	2
ER-CS001X0-VE0I0	SLR0.1 5W J	R137,138,237,238,337,338,437,438	8
ER-CS001X0-VE0I0	SLR0.1 5W J	R137,138,237,238,337,338,437,438	8
ER-HG153X0-HXXXX	THERMISTOR 150K	TH1	1
ER-OG100X0-HA04C	Resistor 10 1W	R16,26,49,50,144,244,344,444	8

PARTS LIST - 2

ER-OG100X0-HA04C	Resistor	10	1W	R16,26,49,50,144,244,344,444	8
ER-OG101X0-T2526	Resistor	100	1/4W	R12,13,27,28,30,37~39,122,123,125,126,222,223,225,226 ,322,323,325,326,422,423,425,426	24
ER-OG101X0-T5039	Resistor	100	1/2W	R101,102,201,202,301,302,401,402	8
ER-OG101X0-T5039	Resistor	100	1/2W	R101,102,201,202,301,302,401,402	8
ER-OG102X0-HA04C	Resistor	1K	1W	R17	1
ER-OG102X0-HA04C	Resistor	1K	1W	R17	1
ER-OG102X0-T2526	Resistor	1K	1/4W	R10,11,127,128,129,215,227,228,229,327,328,329,356,415,427~429,456	18
ER-OG103X0-T2526	Resistor	10K	1/4W	R35,(1,2,3,4),42,(1,2,3,4)43,115,117,120,220,315,317,320,357,420,457	19
ER-OG104X0-T2526	Resistor	100K	1/4W	R354,454	2
ER-OG105X0-T2526	Resistor	1M	1/4W	R29	1
ER-OG122X0-T2526	Resistor	1.2K	1/4W	R118,318	2
ER-OG123X0-T2526	Resistor	12K	1/4W	R31	1
ER-OG124X0-T2526	Resistor	120K	1/4W	R41,43,45,47	4
ER-OG153X0-T2526	Resistor	15K	1/4W	R32,141,241,341,441	5
ER-OG154X0-T2526	Resistor	150K	1/4W	R4,153,253,314,414	5
ER-OG181X0-HA04C	Resistor	180	1W	R19,20	2
ER-OG181X0-HA04C	Resistor	180	1W	R19,20	2
ER-OG182X0-T2526	Resistor	1.8K	1/4W	R(1,2,3,4)07	4
ER-OG184X0-T2526	Resistor	180K	1/4W	R(3,4)52,(3,4)53,(3,4)45,(1,2)14	8
ER-OG220X0-T2526	Resistor	22	1/4W	R2	1
ER-OG221X0-T2526	Resistor	220	1/4W	R14,15,48,51,358,458	6
ER-OG222X0-T2526	Resistor	2.2K	1/4W	R3,7,25	3
ER-OG223X0-T2526	Resistor	22K	1/4W	R1,9,23	3
ER-OG272X0-T2526	Resistor	2.7K	1/4W	R133,233,333,433	4
ER-OG273X0-T2526	Resistor	27K	1/4W	R355,455	2
ER-OG331X0-T2526	Resistor	330	1/4W	R134,234,334,434	4
ER-OG332X0-T2526	Resistor	3.3K	1/4W	R18	1
ER-OG333X0-T2526	Resistor	33K	1/4W	R8,22,40,42,44,46	6
ER-OG470X0-T2526	Resistor	47	1/4W	R130,131,230,231,330,331,430,431	8
ER-OG471X0-T2526	Resistor	470	1/4W	R(1,2,3,4)39,(1,2,3,4)40	8
ER-OG472X0-T2526	Resistor	4.7K	1/4W	R6,21,24,36,132,232,332,432,(1,2,3,4)08	12
ER-OG473X0-T2526	Resistor	47K	1/4W	R(1,2,3,4)09,(1,2,3,4)11	8
ER-OG562X0-T2526	Resistor	5.6K	1/4W	R5(1,2,3,4)10	5
ER-OG682X0-T2526	Resistor	6.8K	1/4W	R121,124,221,224,321,324,421,424	8
ER-OG683X0-T2526	Resistor	68K	1/4W	R103,203,303,403	4
ER-OG683X0-T2526	Resistor	68K	1/4W	R103,203,303,403	4

PARTS LIST - 3

ER-OG824X0-T2526	Resistor 820K 1/4W	R34	1
ES-S23D29X-V0098	Switch SK23D39	SW1,2	2
ET-C1023X0-PY000	Transistor KTA1023-Y	Q9,21,25,26,27,39,51	7
ET-C1027X0-NY000	Transistor KTC1027-Y	Q8,20,38,50	4
ET-C1266X0-PY000	Transistor A1266Y	Q3,4,5,15,16,17,32,34,35,44,46,47	12
ET-C3198K0-NY000	Transistor KTC3198-Y	Q1,2,6,7,12,13,14,18,19,24,31,33,36,37,42,43,45,48,49,54	20
ET-CB688X0-P0000	Transistor KTB688-O	Q11,23,41,53	4
ET-CD718X0-N0000	Transistor KTD718-O	Q10,22,40,52	4
ET-FFZ44X0-X0000	Mosfet IRFZ 44N	Q28,~30,55~59	8
EW-CS06XX0-05AA0	Bare Wire 6MM	J45,46,48,51,52,98,99,101~103,124	11
EW-CS08XX0-05AA0	Bare Wire 8MM	J37,39,42,65,87,92,96	7
EW-CS10XX0-05AA0	Bare Wire 10MM	J3,67,118	3
EW-CS12XX0-05AA0	Bare Wire 12MM	J16,36,38,40,43,44,57,68,100,109,130,137~140	15
EW-CS15XX0-05AA0	Bare Wire 15MM	J4~9,12,13,15,17~19,23~35,53~56,61,63,64,69,75,78,79,90,91,93~95, 104~107,110,115,116,119~122,125~129,131~134,141~146	67
EW-CS20XX0-05AA0	Bare Wire 20MM	J1,2,41,47,49,62,66,76,77,112,117	11
EW-CS25XX0-05AA0	Bare wire 25MM	J21,22,50,71,72,74,80,81,89,135,136	11
EW-CS25XX0-05AA0	Bare Wire 25MM	J21,22,50,71,72,74,80,81,89,135,136	11
II-4558LX0-V0008	IC NJM4558L	U1~3,5~11	10
II-DBL494X-H0016	IC S-494P	U4	1
VR-BN503X0-V0A26	VR 50KB T12	VR1,4	2
VR-BN504X0-V0A26	VR 500KB T12	VR2,5,6	3